

GEONAV 6 ^{SUNSHINE}

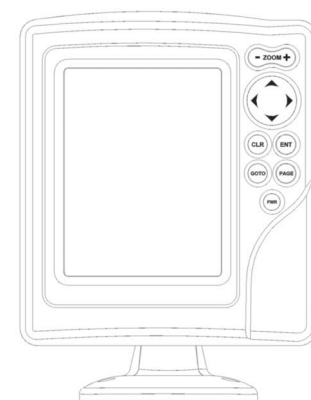

User and Installation Guide

GEONAV 6 ^{SUNSHINE}

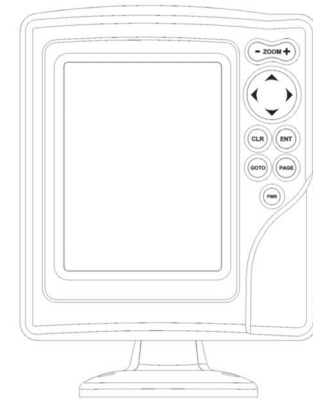

User and Installation Guide

READ THIS WARNING BEFORE USING THE GEONAV

WARNING

THE ELECTRONIC CHART IS AN AID TO NAVIGATION DESIGNED TO FACILITATE THE USE OF AUTHORIZED GOVERNMENT CHARTS, NOT TO REPLACE THEM. ONLY OFFICIAL GOVERNMENT CHARTS AND NOTICES TO MARINERS CONTAIN ALL INFORMATION NEEDED FOR THE SAFETY OF NAVIGATION AND, AS ALWAYS, THE CAPTAIN IS RESPONSIBLE FOR THEIR PROPER USE.

The use of the GEONAV implies knowledge and acceptance of this warning by the user.

NOTE: The technical characteristics and functions described in this manual are subject to change as a result of improvements or changes to the product.

INTRODUCTION

The GEONAV is a chart plotter that displays your boat's current position with respect to an electronic chart.

The unit can be optionally equipped with a built-in GPS receiver that can track up to 12 satellites simultaneously and be interfaced with:

- An external GPS
- A depth sounder
- An autopilot

By using a GEONAV and a NAVIONICS electronic chart, you will never get lost even in bad weather conditions such as fog, rain or dark because your plotter will always display where you are and where you are heading to.

The ROUTE function will allow you to plan a trip, MARKERS will allow you to mark points of interest whereas the TRACK function will allow you to record your actual route. Thanks to the unlimited capacity of the new CompactFlash™ cartridges - that can also be used on PCs as personal hard disks - the instrument can store a large amount of route, track and marker data.

NAVIONICS GOLD CHARTS are available for all the most popular boating areas and can be used in addition to official paper charts to obtain additional information, such as the availability of port services, as well as tides and currents data. NAVIONICS electronic charts are available worldwide from authorized NAVIONICS dealers.

Should new functions be available in the future, it will be possible to update the GEONAV internal software at any NAVIONICS dealer.

CHARACTERISTICS

General characteristics

GPS inside model

- Compact chart plotter with optional built-in GPS receiver and antenna
- 12-channel internal GPS (optional)
- Satellite acquisition time:
2 minutes (cold)
15 minutes first fix (with internal GPS)
- GOTO function (Port, Nearest Service, Marker, Lat/Lon)
- External GPS interface via NMEA 0183
- Depth sounder interface via NMEA 0183
- Display of depth and water temperature data (if interfaced with an echosounder)
- Autopilot interface via NMEA 0183
- Chart Rotation (head-up display)
- Screen Amplifier™ function
- Autozoom™ function
- Overzoom™ function
- 8 marker shapes, 8-character name
- Reverse route function
- Selectable depth units (meters, feet and fathoms)
- Cartography with port services and Tides and Currents data
- 16 zoom levels
- Heading vector
- CompactFlash™ cartridge
- Storage of routes, tracks and markers in separate files on CompactFlash™ cartridges
- Built-in world map
- Splash-proof
- Weight: 1 kg

Electrical characteristics

- Input voltage: 9.8VDC to 18 VDC with protection against reverse polarity and overvoltage
- Power consumption: 10 W

- Operating temperature: 0° to +60° C, humidity 93%
- Storage temperature: -20°C to +70°C, humidity 93%
- Color LCD, TFT 5.6", sunlight visible
- Adjustable backlight and contrast
- Backlight keypad
- Pixel resolution: 240 x 320
- 32-bit RISC processor

Memory characteristics

- Up to 20 waypoints per route
- Up to 500 trackpoints
- Up to 99 markers per group
- Number of routes, tracks and markers: unlimited, depending on the size of the CompactFlash™ used

Interface characteristics

- Standard NMEA 0183 sentences
 - from the position sensor: GLL, VTG, GGA, RMC, GSV, ZDA, RMA, GSA
 - from the depth sounder: DBT, MTW
 - to the autopilot: APA, APB, XTE, RMB, BWC, GLL, VTG

If received from the GPS, the following sentences are transmitted:

GGA, RMC, ZDA

Accessories

- Bracket for fixed installation
- Gasket and drilling template for panel mounting
- Data cable for connection to external GPS, depth sounder and autopilot
- User's manual
- Carrying case

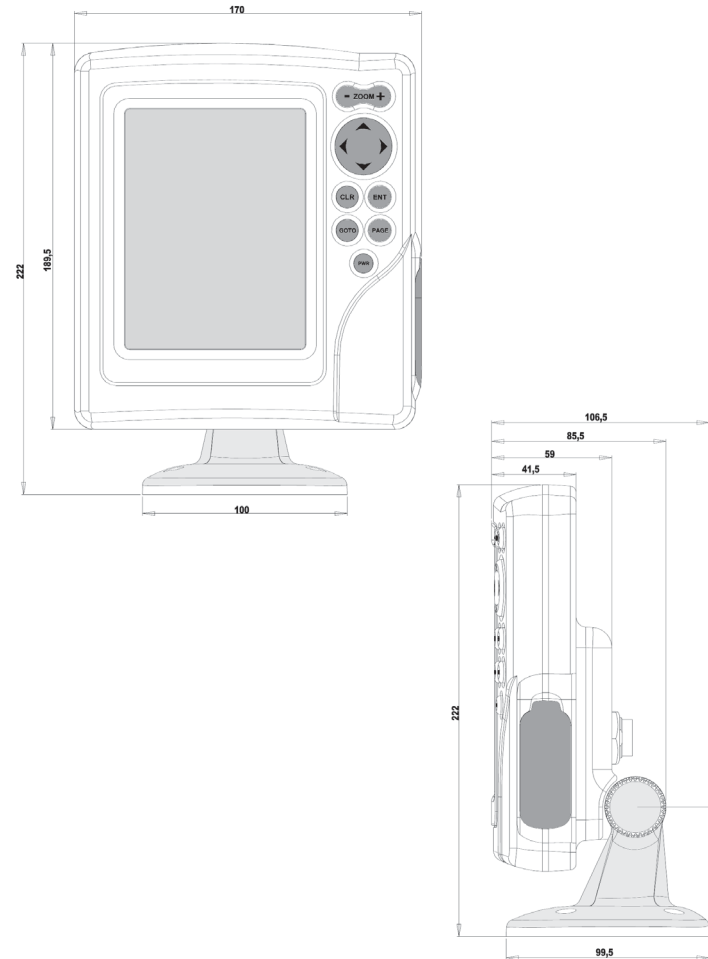

INSTALLATION AND PRECAUTIONS

To avoid electromagnetic interference, the GEONAV must be positioned at least 0.35 meters away from magnetic compasses or flux-gate sensors, such as those used on autopilots and remote electronic compasses.

The GEONAV is water resistant, but not waterproof. It is essential that the rubber cover on the right side of the unit is firmly inserted into the cartridge slot; the rubber cover should be removed only when the CompactFlash™ has to be inserted or replaced and, in this case, the unit must be perfectly dry.

NOTE: Any damage caused by the presence of water inside the cartridge slot, due to the cover missing or incorrectly replaced, is specifically excluded from the warranty.

Cleaning

It is recommended that you use a non-alcoholic product to clean the glass, since alcoholic products may damage the glass surface or make it opaque.

Installation

The GEONAV allows using either the built-in antenna for outdoor installation or an external GPS antenna for indoor use.

NOTE: At start-up, the plotter will select the internal GPS by default.

- **Internal GPS (if available):** For the best reception of satellites, mount your unit in an open area to allow the built-in antenna to have the best sky visibility. If the instrument is installed so as to allow full horizon visibility, the best performance will be ensured.
- **External GPS:** Instead of a built-in antenna, you can use an external GPS. To connect the GEONAV to an external antenna, use the data cable provided with the unit (see the *Connections Section*).

- **Autopilot:** To connect the GEONAV to an autopilot, use the data cable provided with the unit (see the *Connections Section*).
- **Depth sounder:** To connect the GEONAV to a depth sounder, use the data cable provided with the unit (see the *Connections Section*).

Fixed mounting

The plotter can be mounted on any surface using the mounting bracket provided with the unit (see figure).

Use 4 flat-head screws (5mm) to fix the bracket to the desired mounting surface. Since the bracket does not allow any left or right rotation, make sure that the unit is properly installed for the best view angle.

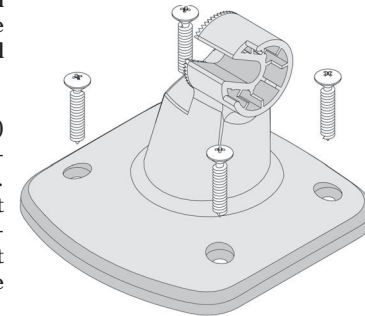

Panel mounting

Locate the area where the GEONAV is to be installed, then use the drilling template supplied with the plotter to properly cut holes and sockets out of the instrument's panel.

The neoprene adhesive gasket supplied must be applied to the GEONAV rear side to avoid moisture penetration and to reduce vibrations.

Mounting screws must be 4 mm in diameter and maximum 5 mm in length, plus the thickness of the panel. Do not exceed tightening the screws, in order to avoid damaging the screw seats.

CONNECTIONS

Power supply and data cable

- | | | | |
|-----------------------------|-----------------|-------|--|
| 1. Power supply | | | |
| red wire | +VDC | pin 1 | |
| black wire | GND | pin 2 | |
| 2. Data input ext. GPS | | | |
| brown wire | ext. GPS in + | pin 3 | |
| yellow wire | ext. GPS in - | pin 4 | |
| 3. Data output | | | |
| violet wire | Autopilot out + | pin 5 | |
| white wire | Autopilot out - | pin 6 | |
| 4. Data input depth sounder | | | |
| blue wire | DS in + | pin 7 | |
| green wire | DS in - | pin 8 | |
| SHIELD | | pin 9 | |

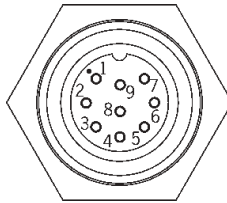

If sent by the autopilot, the following NMEA messages are transmitted to external devices: GGA - RMC - ZDA

The GEONAV will add the following messages: APA - APB - XTE - RMB - BWC - GLL - VTG

The data cable is supplied together with the GEONAV plotter.

WARNING: Once the installation is completed, always make sure that all wires are properly connected since wrong connections may damage the unit.

CARTRIDGE INSTALLATION

Installing the CompactFlash™

Remove the rubber cap from the cartridge slot located in the right-hand side of the plotter.

Insert the cartridge into the appropriate slot, with the label side (side with a small arrow) backwards and push it.

Replace the cap exercising firm pressure and check that it is perfectly closed, in order to avoid any water infiltration.

NOTE: Make sure of inserting the cartridge correctly. Should you try to insert the wrong side of the cartridge, full insertion into the slot is hampered. Any further attempt to force the cartridge into the slot may damage the cartridge or the plotter. This kind of damage is not covered by the warranty.

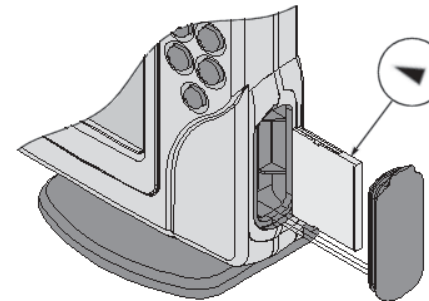

Removing the CompactFlash™

Make sure that the plotter is perfectly dry.

Remove the rubber cap from the cartridge slot located in the right-hand side of the plotter, then extract the cartridge.

WARNING: The rubber cover should be removed only when inserting or replacing the cartridge.

WARNING: Always use CompactFlash™ cartridges certified by Navionics. The use of non-certified cartridges may result in improper operation of the unit.

The CompactFlash™ cartridges can be used as a mass-storage with any PC computer, so can be the cartridge used by the plotter. However, the plotter needs to find some free space in the cartridge in order to work properly. Prior to use a new cartridge, always make sure that there are at least 2.5MB of free space.

WARNING: Be careful when handling the cartridge files by using the PC. Windows allows deleting and moving files easily, therefore pay attention when using Windows Explorer not to erase the content of the \NAVIONIC and \GEONAV folders. Damaging the files stored in such directories may result in loss of data or improper operation of the unit.

KEYBOARD

ZOOM+/ZOOM-
Selects the chart range.

ENTER
Enters a waypoint or a marker, or confirms a selection from the menu.

PAGE

- Navigation mode:
Turns navigation data pages.
- Cursor mode:
Allows switching from Cursor mode to Navigation mode.

GOTO
Allows plotting a route toward a manual cursor position, desired marker, port, nearest port service or specified position (lat/lon).

CLR

- Navigation mode:
Deletes the current route.

- Cursor mode:
Deletes the last waypoint or the marker pointed by the cursor.

CURSOR

- Moves the manual cursor across the screen.
- Allows switching from Navigation mode to Cursor mode.
- Allows selecting from the options in the menu /submenu.
- At start-up, allows adjusting the screen contrast.

PWR

- Switches the GEONAV on / off.
- Allows adjusting the screen backlight.
- Allows adjusting the screen contrast.

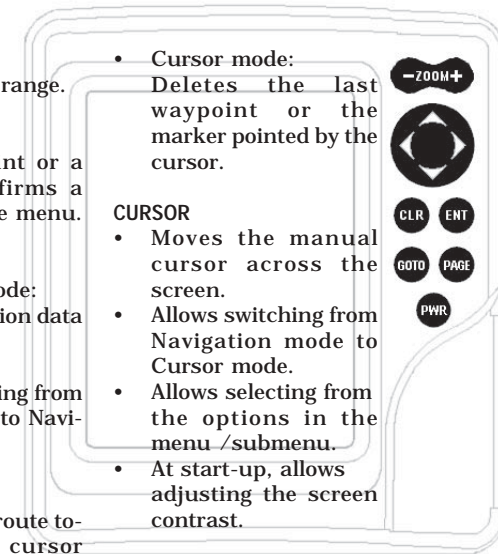

DIAGNOSTIC

The GEONAV features a diagnostic program to verify its correct performance, once installed, and to detect problems that may occur during the use of the unit.

To access the diagnostic program, keep pressed any key but CLR, while pressing the PWR key.

The GEONAV will switch on and carry out automatically a test of the whole system; as soon as the memory test is completed, the program will test the LCD, the CompactFlash™ card and the keyboard. Press ENTER to run one test, CLR to skip to the next one. To exit from the keyboard test, press CLR twice.

Once the keyboard test is completed, the diagnostic program allows checking the messages received from the GPS through the NMEA 0183 port. Hold the ENTER key pressed to freeze the messages on the screen, then release it to keep on displaying the new messages sent by the GPS. To test channel 2 (depth sounder or wind instrument), press GOTO. Press CLR to quit.

After the keyboard, the diagnostic program will test the internal GPS (if available) and the backlight. Press ENTER to run one test, CLR to skip to the next one.

Once terminated all tests, press ENTER to re-boot the unit.

WARNING: The internal memory can be cleared by pressing simultaneously the PWR and CLR keys. This operation will delete all the settings stored in the GEONAV and restore factory settings.

NOTE: In case of damaged cartridge or abnormal power spikes, the unit might lock, requiring a power shutdown to restart. In that case, the unit can be turned off without the need of detaching the power, by simply pressing the GOTO, PAGE and CLEAR keys at the same time. This function is useful if the unit is panel mounted or flush mounted and the power switch cannot be easily accessed.

NAVIONICS ELECTRONIC CHARTS

The GEONAV includes a built-in world map that allows zooming from 4,096 down to 512NM. Additional cartography details relative to a specific area of navigation are available from the CompactFlash™ cartridges storing NAVIONICS GOLD CHARTS.

To display chart boundaries, press PAGE until the menu bar appears, select SETUP, CHART BOUNDARIES, then select ON/OFF to enable/disable the boundaries of the charts stored in the cartridge. A small square will locate the area covered by the cartridge installed.

Increasing/decreasing the chart range

Press the -ZOOM+ key.

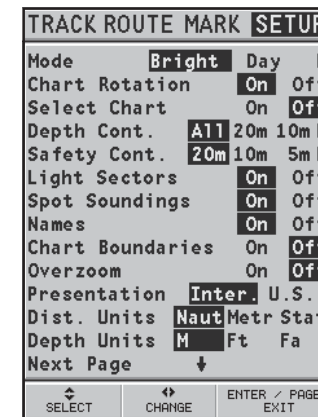

Displaying depth and safety contours, geographical names, spot soundings and light sectors

Press PAGE to display the menu, select SETUP and enable the option desired (Depth Cont., Safety Cont., Spot Soundings, Names or Light Sectors) by using the CURSOR key.

Converting depth values into the units set

Press PAGE to display the menu, select SETUP, DEPTH UNITS and then set the unit desired to meters, feet or fathoms.

The GEONAV will convert all the depth values in the unit selected, making them appear like those reported in the official nautical charts (see the figure).

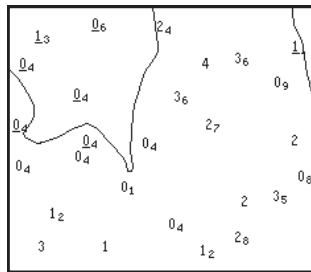

Displaying abbreviated navaid characteristics
 Position the manual cursor on the navaid symbol.
 A window will show the abbreviated characteristics relative to the navaid selected.

Description of abbreviated navaid characteristics:

ABBREVIATIONS FOR LIGHT		ABBREVIATIONS FOR COLOUR	
AL	alternating	AM	amber
F	fixed	B	black
FLL	fixed and flashing	BL	blue
FL (...)	group flashing	G	green
FL	single flashing	OR	orange
IQ	interrupted quick	R	red
OC	single-occluding	VL	violet
OC (...)	composite group occulting	W	white
Q	continuous group	Y	yellow
ABBREVIATION FOR PERIOD		ABBREVIATION FOR RANGE	
..S	xx seconds	..M	xx nautical miles

Displaying object attributes

Move the manual cursor on top of an object on the chart, then press GOTO and select INFO. A window will show the description of all the objects present on the chart at the cursor position. Select one object from this window and press ENTER to show all of the object attributes.

The objects that can be queried include depth contours, depth areas, point objects (lights, navaids, landmarks, etc.), land areas, spot soundings, coastlines, rocks, wrecks and in general any symbol present on the chart.

Changing chart symbols

The symbols used to represent the objects on the chart (buoys, lights, landmarks, etc.), as well as chart colors, can be selected between paper-chart International or US styles.

Press PAGE to display the menu, select SETUP, then move the cursor to the next page and select PRESENTATION (INTER. or US).

Displaying port services

NOTE: This function is available only with the NAVIONICS cartridges containing the Port Services feature.

 This symbol identifies a port providing services.

Zoom down to 1 NM, position the manual cursor on the icon (sailing boat) relative to the selected marina.

By pressing ENTER, a window will list all the services available in that port.

Select the desired icon by using the CURSOR key.

Port services are identified by the icons shown in the table on the following page.

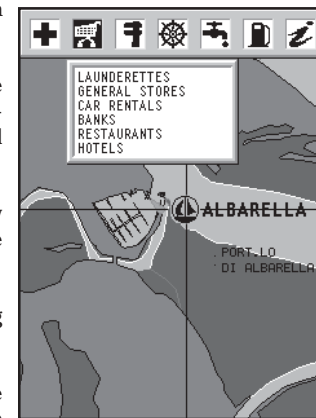

The number and the type of service available will depend on the NAVIONICS cartridge installed.

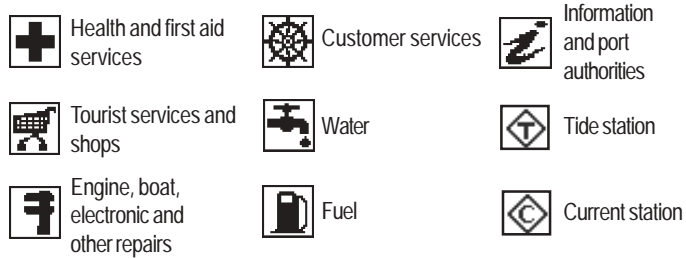



Displaying Tides and Currents data

NOTE: This function is available only with the NAVIONICS cartridges containing Tides and Currents data.

Position the cursor on the icon of a Tide or Current station, then press ENTER.  

A graph will show the tide rate or the tidal stream relevant to the station selected, as measured during the current day.

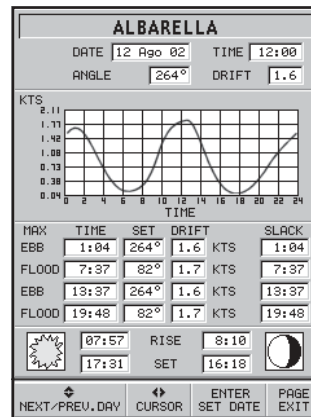
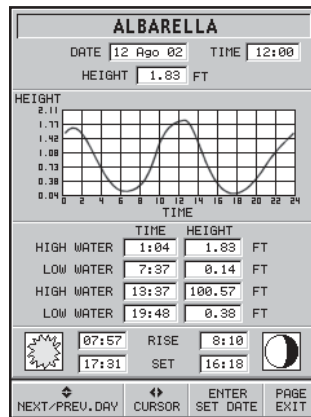

GRAPHIC ITEMS

Besides chart data, the GEONAV displays some graphic items useful during navigation. The figure below shows some of these items.

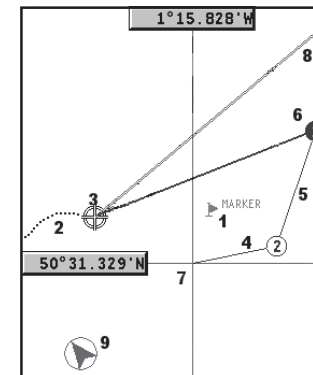

- 1 - Marker
Indicates a point of interest associated with a symbol and a name.
- 2 - Track segment
Recording of the track actually followed by the boat; the track is displayed as a dashed line.
- 3 - Boat's position
Boat's position according to the data received from the GPS receiver.
- 4 - Rubber band
Line joining the last waypoint entered to the manual cursor, or the boat's position to the manual cursor when no waypoint has been entered.

To delete this band, press the PAGE key and switch to Navigation mode.

5 - Route leg

Part of route between two waypoints.

6 - Waypoint

Waypoints are identified by a circle and a number. The route starting point is marked by the "X" symbol. The target waypoint is identified by a filled circle, whereas the route leg currently followed is identified by a thicker line.

7 - Cursor

Indicates the position expressed in geographical coordinates (latitude and longitude).

It is displayed when the plotter is in Cursor mode.

8 - Heading vector

Indicates graphically the boat's current route.

9 - North indicator

Indicates the north direction when the Chart Rotation function is enabled.

FUNCTIONAL CHARACTERISTICS

This chapter describes some of the most important functions of the GEONAV, as well as the terms most commonly used in this document.

Switching on/Switching off the unit

To switch the GEONAV on, press the PWR key. To switch it off, keep the PWR key pressed for more than 3 seconds.

Internal or external GPS

To make the installation easy, the GEONAV can use either its own internal GPS receiver (if available) or an external receiver, depending on where the unit is to be installed (indoor or outdoor).

To select the internal/external GPS, press PAGE to display the menu, select SETUP, then GPS INT or GPS EXT.

Depth sounder

When in depth sounder mode, the GEONAV displays the navigation window in the screen upper part, and, in the bottom part, the sea depth in graphic form.

The depth value can be expressed in meters (selected by default), feet and fathoms; press PAGE to display the menu, select SETUP and then DEPTH UNITS (M/FT/FA).

Navigation mode (Automatic)

The GEONAV enters the Navigation mode as soon as the internal or external GPS receiver transmits a valid fix; when in Navigation mode:

- The manual cursor is not displayed
- The depth sounder window can be accessed

This mode is also called automatic because the unit automatically selects the chart scale and updates the boat's position on the screen.

GPS inside
model

Cursor mode (Manual)

When in Cursor mode, the manual cursor is displayed. It is possible to edit a route, insert or delete markers, display navaid information etc., but it is not possible to gain access to the depth sounder window. By pressing one of the four arrows in the CURSOR key, the unit switches from Navigation to Cursor mode, and the screen is centered in relation to the manual cursor. To return to Navigation mode press PAGE.

Chart rotation

Charts are traditionally displayed in north-up mode. This, however, does not correspond to reality. For example, when traveling southwards, the chart shows, on the right side of the boat, what is actually located on the left side, and vice versa.

The Chart Rotation function allows rotating the electronic chart displayed according to the plotted route (COG - Course Over Ground) as detected by the GPS receiver. Since the COG value varies continuously, a filter has been inserted to prevent the chart from bouncing.

To activate the Chart Rotation function, press PAGE to display the menu, select SETUP, then CHART ROTATION and ON. A message will prompt the user to select the requested maximum range before activating the chart rotation. The northern direction will be indicated by the symbol .

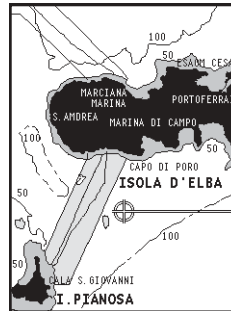

Without rotation

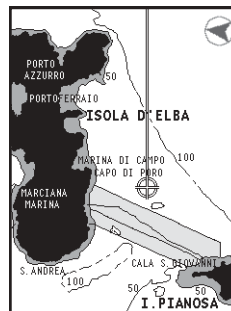

With rotation

Autozoom

With the Autozoom function the GEONAV will always display automati-

cally the boat's position and the target waypoint at the best available chart range. As the boat approaches the target waypoint, the unit will automatically zoom in. Once the waypoint is passed, the unit will select the best range to display the boat's position and the following waypoint.

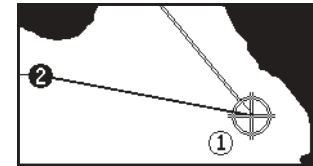

To activate the Autozoom function, press ZOOM+ until the "AUTOZOOM ? ENTER = YES" message is displayed. To deactivate the Autozoom function, press the ZOOM key once.

When the GEONAV is turned on, and if at least one waypoint has been previously entered, the Autozoom function is automatically activated.

Screen Amplifier

This function automatically redraws the chart according to the boat's course, to maintain 2/3rds of the screen ahead of the boat, provided that the boat's speed is greater than 3 knots. This function will be activated only if no waypoint has been previously inserted.



Without screen amplifier



With screen amplifier

Overzoom

The Overzoom function allows the chart scale to expand anywhere up to 1/4 NM. The Overzoom does not provide any additional chart detail, but improves only the readability of the existing information, thus acting as a magnifying glass. When the Overzoom is activated, the unit will warn the user by

replacing RANGE with OVZ (blinking) within the navigation window.

To activate/deactivate the Overzoom function, press PAGE until the menu bar is displayed, then select SETUP, OVERZOOM and ON/OFF.

Position calibration

Most position sensors have intrinsic errors that make the boat's position incorrect (from few meters to several hundred meters) with respect to the background display of the chart. This error is caused by the principle at the root of the satellite-derived position system.

The position calibration allows the user to manually correct the position error present in all GPS. Press PAGE until the menu bar is displayed, select SETUP, CALIBRATION and then ON.

A message will prompt the user to move the cursor to the boat's true position by using the CURSOR key. Press ENTER to move the GPS boat's position to the point indicated by the cursor. This operation will save the calibration for use in future calculations.

NOTE: When the calibration is activated, the coordinates will be marked by (*).

To cancel calibration, press PAGE until the menu bar is displayed, select SETUP, CALIBRATION and then OFF.

Local time

By this function the user can enter local time instead of the Greenwich time (GMT) supplied by the GPS receiver.

To enter local time, press PAGE until the menu bar is displayed, select SETUP, SET TIME and then LOCAL.

A window will allow entering local time by using the CURSOR key. Press ENTER to confirm the operation.

To cancel local time, press PAGE until the menu bar is displayed, select SETUP, SET TIME and then GMT.

Chart presentation

This function allows the user to select the symbols and colors of chart presentation between International mode and US mode.

To change the chart presentation mode, press PAGE to display the menu, select SETUP, PRESENTATION and then choose the option desired.

Display mode

The chart color can be selected among three predefined modes: BRIGHT (bright light), DAY (normal light) and NIGHT (poor light).

Press PAGE to display the menu, select SETUP, MODE and then choose the option desired.

Depth contours

This function allows the user to select the display of depth contours; the options available are:

- OFF: no depth contour displayed
- 5m: display of contours only with depths up to 5 meters
- 10m: display of contours only with depths up to 10 meters
- 20m: display of contours only with depths up to 20 meters
- ALL: all depth contours are displayed

Safety contours

This function allows the user to display the depth areas corresponding to the safety contour desired. The options available are:

- OFF: no depth area displayed
- 2m: areas with depths up to 2 meters in dark blue
- 5m: areas with depths up to 2 meters in dark blue, up to 5 meters in blue
- 10m: areas with depths up to 5 meters in dark blue, up to 10 meters in blue

20m: areas with depths up to 10 meters in dark blue, up to 20 meters in blue

The areas whose depths are over the limit set, and therefore navigable under safety conditions, will be displayed in white. Dryline areas are always displayed in green.

NOTE: The mentioned colors are those used in the DAY mode. In NIGHT mode, the areas with depths over the limit set, and therefore navigable under safety conditions, are in black, whereas the colors below the limit are dark blue for higher depths and blue for lower depths (e.g., 5m: areas with depths up to 2m displayed in blue, up to 5m in dark blue).

Chart loading

At start-up, the list of the NAVIONICS electronic charts stored in the cartridge is shown, provided that a CompactFlash™ cartridge has been inserted.

Select the chart desired by CURSOR, then confirm by ENTER. Each time the unit is switched on, the latest chart used will be loaded.

To load another chart stored in the CompactFlash™, press PAGE to display the menu, select SETUP and then SELECT CHART.

Contrast/Brightness

Press the PWR key to display the CONTRAST/LIGHT window. To switch from one option to the other and to adjust the contrast/brightness level, press CURSOR. Press the PAGE key to exit.

The contrast can be adjusted at start-up, when the WARNING message appears or when the satellite window is displayed; press the ZOOM key and adjust the contrast.

GETTING STARTED

We recommend that you use the GEONAV intuitively, since no damage will be caused by pressing an incorrect button.

Make sure that the unit is powered, insert a CompactFlash™ cartridge and then press PWR. At start-up, the last chart used will be loaded by default. If the chart is not found, the list of NAVIONICS charts stored into the CompactFlash™ cartridge will be displayed. Select the desired chart by the CURSOR key, then confirm by pressing ENTER.

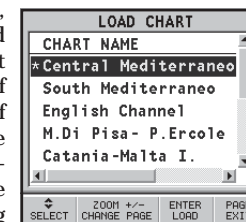

A message will warn the user that electronic nautical charts do not replace official government charts.

Press the PWR key to turn the display backlight on and adjust brightness by the CURSOR key; press PAGE to continue.

The Satellite window will show the configuration of the satellites in use.

As soon as the GPS receiver has obtained a valid fix (it can take a few minutes), the boat's position and the relevant area will be displayed at the best scale available.

The default language is English. To change the language, press PAGE to display the menu, then select SETUP, LANGUAGE and the desired language by the CURSOR key.

The line, or vector, starting from the boat indicates the boat's direction, to be ignored if the boat is stationary.

The window situated in the lower part of the screen will display the boat's speed, route and chart scale.

The GEONAV is in Navigation mode; by pressing the CURSOR

key, it is possible to switch to Cursor mode (editing mode). The cursor geographical position is shown by two windows.

To plot a route starting from the boat's position, move the cursor to the position desired, and press ENTER to insert a waypoint at the cursor's position, that will be indicated by a circle containing the number 1.

The windows will show distance, bearing and the time to reach the target waypoint.

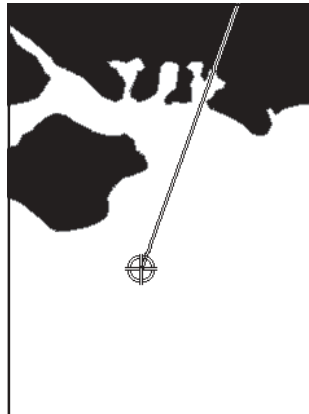

Press the PAGE key to go back to Navigation mode.

To add more waypoints, press CURSOR and repeat the operations described above.

As new waypoints are added, the numbering will increase progressively. In case of error, waypoints can be deleted by pressing the CLR key (Cursor mode), starting from the last entered. To go back to Navigation mode, press PAGE.

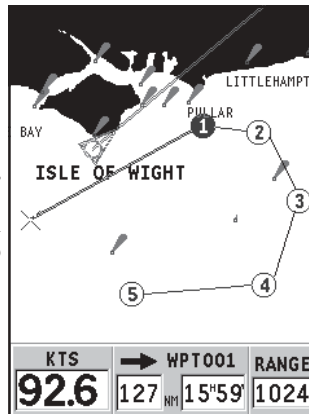

If an autopilot is connected to the GEONAV, the plotted route is automatically followed as soon as the Navigation mode is enabled.

NOTE: The cursor can be moved to the desired position by using the GOTO function as well. See the *GOTO* Section for more details.

OPERATING MODES

The GEONAV can operate in two different modes, Cursor and Navigation, each giving access to different functions.

CURSOR MODE

When the GEONAV is in Cursor mode, the crosshair cursor is displayed. The CURSOR key allow browsing through the electronic chart, as well as editing or creating the route. See the *Route Section* for more details.

To enter the Cursor mode, press the CURSOR key.

NAVIGATION MODE

In Navigation mode, the boat's position icon replaces the crosshair cursor and several data windows can be accessed. To enter the Navigation mode, press the PAGE key repeatedly. As the fix is valid, the windows sequence is the following:

SATELLITE > NAVIGATION > MENU > DEPTH SOUNDER > TRIP > INFO

The Depth Sounder window is displayed provided that data is received from a depth sounder.

The Info window is displayed provided that a NAVIONICS cartridge featuring Tides and Currents data is active (see the *Info Window Section*).

SATELLITE WINDOW

NOTE: If a NAVIONICS cartridge with the Tides and Currents feature has been inserted, the Satellite window will disappear as soon as a valid fix is obtained and be replaced by the Info window.

At start-up the satellite window displays how many and which satellites are tracked by the GPS receiver.

The outer circle represents the horizon, the inner one identifies a 45° elevation with respect to the horizon, and the central circle points to the zenith. The small squares with numbers show the satellites available.

As soon as a satellite is tracked by the GPS receiver, the square turns red. The bars displayed on the left identify the signal quality; the longer the bar, the higher the signal quality.

On the left of each bar, two digits indicate numerically the signal/noise ratio.

Additional information:

- Day, month, year, local or Greenwich time (at the first start-up the GEONAV is initialized to Greenwich Time).
- Boat's position (lat/lon) (or the latest valid fix if the GPS receiver is still searching for satellites).
- Data on the current satellite situation (number and fix).
- SOG, COG and altitude.

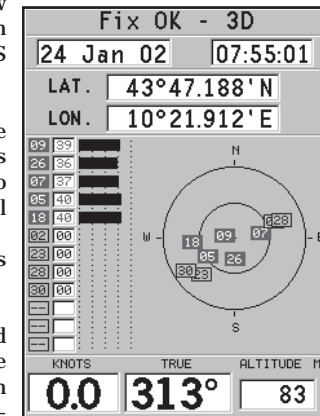

The latitude and longitude values relevant to the boat's position are displayed as soon as three satellites are tracked and a 2D fix (two dimensions) is available.

The altitude value is available only if four satellites are tracked and a 3D fix is obtained.

As soon as a valid fix is available, the GEONAV will automatically switch to Navigation mode and display the boat's position at the best chart range available; the window at the bottom of the screen will indicate the boat's course and speed.

NAVIGATION WINDOW

This window is activated automatically as soon as the GPS receiver has obtained the boat's position (FIX OK).



, course and chart range are dis-
screen.

chart detail level can be increased,
chart data.

d, the screen will display the fol-

- Boat's speed
- Distance from the target waypoint
- Time to arrive to the target waypoint
- Chart range



MENU

The menu bar, displayed at the top of the screen, allows selecting from the following options:

TRACK ROUTE MARK SETUP

TRACK: To activate/deactivate the track function and to delete a track saved.

ROUTE: To delete, reverse, store, recall a route and display route information.

MARK: To delete, store and recall markers.

SETUP: To activate/deactivate the plotter's setup.

DEPTH SOUNDER WINDOW

A depth sensor can be interfaced with the GEONAV via NMEA.

In this case, the GEONAV automatically enables the depth sounder function, displaying a graph of sea depth.

The depth scale, whose unit can be selected from the menu in meters, feet or fathoms, will change automatically to show deeper or shallower water.

In Navigation mode, press PAGE until the depth sounder window appears.

The window will display the following data:

- Water depth
- Depth scale
- Water temperature (if available)

When navigating in waters deeper than sounder access range or if the boat's speed is too high for depth sounding, data acquisition will be interrupted and the number replaced by "—".

To deactivate the depth sounder window, press PAGE.

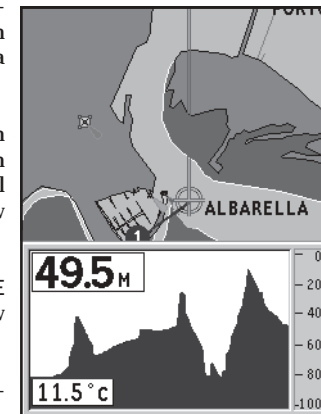

INFO WINDOW

When a NAVIONICS cartridge featuring Tides and Currents data is present, this window displays further information, besides the forecast data supplied by selecting the Tides and Currents station.

The following data is displayed:

- Latitude and longitude at the current boat's position
- Current time and date
- Value of magnetic variation received by the GPS
- Dawn and sunset time
- Moonrise and moonset time
- Moon phase
- Graph of estimated tide level with respect to the current position

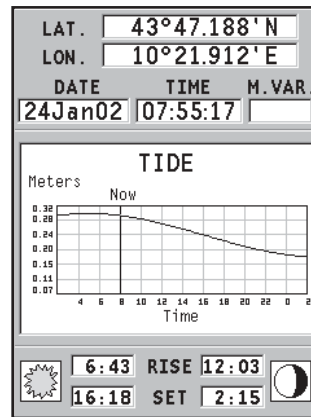

WARNING: Unlike the graph displayed at a T&C station position (accessible through the GOTO function, or by positioning the cursor on the Tides and Currents station symbol) which is as accurate as supplied by hydrographic offices, this graph shows estimated data, being the result of interpolation between the two Tides and Currents stations nearest to the point of interest. The accuracy of the estimate may vary, depending on the coast type, the distance to the nearest stations, and other geographical features.

TRIP WINDOW

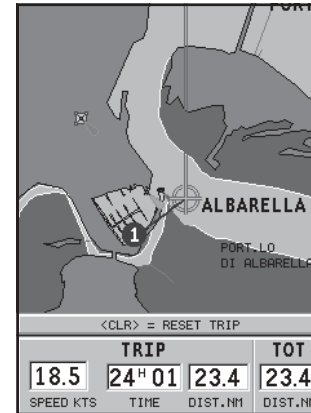

The trip window shows the data relating to the route followed and, in particular:

- Average speed
- Time elapsed from departure
- Partial distance covered
- Total distance covered

To reset partial counters before starting a new journey, press CLR.

ROUTE

EDITING A ROUTE (CURSOR MODE)

Creating a waypoint

Using the **CURSOR** key, move the cursor on the position desired and press **ENTER** to insert a waypoint.

To enter further waypoints, move the cursor and press **ENTER**. The new waypoint will be appended to the existing route.

Up to 20 waypoints per route can be entered by using the **GOTO** function as well (see the *GOTO* Section).

Deleting the last waypoint

Press **CLR**. If the last waypoint is out of screen, the "DELETE WP? ENTER = YES" message will be displayed.

Press **ENTER** to confirm the deletion.

Deleting a waypoint

Use the **CURSOR** key to position the cursor on the waypoint to delete and press **CLR**.

Deleting all waypoints in a route

Press the **CLR** key repeatedly until the "NO WP PRESENT" message is displayed.

Moving a waypoint

Position the cursor exactly on the waypoint to move; press **ENTER** to capture the waypoint, then move the waypoint to the position desired and confirm the operation by pressing **ENTER**.

Inserting a new waypoint in a route

Position the cursor exactly on the route leg to edit and press **ENTER** to capture the leg.

Once captured, the leg will show a thicker line to distinguish it more easily from the other route legs. A window will also

show the leg captured.

Move the manual cursor to the position desired, insert the new waypoint and confirm by pressing **ENTER**.

EDITING A ROUTE (NAVIGATION MODE)

If the manual cursor is displayed, press the **PAGE** key to enter Navigation mode.

Changing the target waypoint

Use the "Route to a waypoint" function (see the *GOTO* Section).

WARNING: The route will be modified and the new target waypoint selected will be the first waypoint in the route.

Deleting all waypoints

Press the **CLR** key to show the "DELETE ROUTE? ENTER = YES" message. Press the **ENTER** key to confirm the deletion or another key to exit.

FUNCTIONS IN THE ROUTE MENU

Route Info

Route information is displayed in two pages; the first shows general route information, whereas the second contains the geographical coordinates of all waypoints.

Press the **PAGE** key repeatedly to display the menu bar, select **ROUTE**, **INFO** and then press **ENTER**.

A window will show the following information:

WP NO.: Waypoint ID

DISTANCE: Distance from **START** to current waypoint

TIME: Estimated time from **START** to current waypoint

FUEL: Estimated fuel consumption (liters)

The time to arrive to the waypoint and fuel consumption are displayed provided that estimated speed and fuel consumption values have been entered (see the *Entering speed and fuel consumption data* Section).

To switch to the next page showing the geographical coordinates of each waypoint, use the CURSOR key. Go back to the previous page by using CURSOR or press the PAGE key to exit.

WP NO.: Waypoint ID

POSITION: Waypoint latitude and longitude

Entering speed and fuel consumption data
This piece of information is used to calculate the values displayed in the ROUTE INFO window.

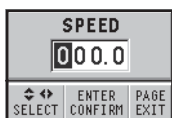

Press the PAGE key to display the menu, select ROUTE, INFO and press ENTER.
Enter the data required and confirm by pressing ENTER.

WP NO.	DIST. KM	TIME	FUEL L.
START			
END	0.36	1h11'	54

SPEED	100	KM/H	FUEL/H	100
CHANGE PAGE	ENTER INPUT	SPEED/CONS.	PAGE EXIT	

WP NO.	POSITION
START	LAT. 50°52.060 N LON. 170°14.890 W
END	LAT. 12°08.777 S LON. 100°25.500 E

ENTER / CHANGE PAGE	PAGE EXIT
---------------------	-----------

Storing a route in the CompactFlash™
Press the PAGE key to display the menu, select ROUTE, STORE and press ENTER. To change the default name and to confirm the operation, use the CURSOR key.

The “ROUTE STORED” message will confirm that the route has been stored correctly. Once stored, the route will disappear from the screen.

Recalling a route from the CompactFlash™

Press the PAGE key to display the menu, select ROUTE, RECALL and press ENTER to open the route catalog; select the route by the CURSOR key and then press ENTER to confirm, or PAGE to exit.

The route recalled will be displayed, the Autozoom function automatically enabled and a window will allow selecting the target waypoint.

Deleting a route

Press the PAGE key to display the menu, select ROUTE, DELETE and press ENTER to confirm.

The catalog that lists the routes stored in the CompactFlash™ will show the CURRENT item indicating the route currently displayed. Select the route to delete by the CURSOR key, then press ENTER to confirm.

By selecting CURRENT, the route currently displayed will be deleted; the route can also be deleted by pressing the CLR key while in Navigation mode.

TRACK ROUTE MARK SETUP		
RUT00001	05 feb02	10:45
RUT00002	-----	--:--
GORGONA	10 Ago02	12:20

RUT00003			
SELECT	MOVE	ENTER CONFIRM	PAGE EXIT

ZOOM + NEXT PAGE	ZOOM - PREV. PAGE	PAGE EXIT
------------------	-------------------	-----------

Reversing a route

Press the PAGE key to display the menu, select ROUTE and then REVERSE (if no route is currently displayed, the "NO ROUTE PRESENT" message is displayed).

The waypoint order will be automatically reversed allowing navigation in the opposite direction. To display information on the new route, select the ROUTE/INFO option.

TRACK

The Track function allows recording the track actually followed by the boat. The Track function can be enabled and disabled several times during navigation; in this case, separate track segments will be drawn.

Starting a track

To enable the Track function, press the PAGE key to display the menu bar, select TRACK, START and press ENTER to confirm. A small circle on the boat's position will indicate the track starting point.

Stopping a track

To disable the Track function, press the PAGE key to display the menu bar, select TRACK, STOP and press ENTER to confirm.

Storing a track in the CompactFlash™

Press the PAGE key to display the menu bar, select TRACK, STORE and press ENTER to confirm. To change the default file name and confirm the operation, use the CURSOR key.

The "TRACK STORED" message will confirm that the track has been stored correctly. Once stored, the track will disappear from the screen.

Each time a track is stored in the CompactFlash™, the plotter's memory is cleared and the indicator of memory used in the TRACK menu is reset to 0%.

Recalling a track from the CompactFlash™

Press the PAGE key to display the menu bar, select TRACK and then RECALL to open the track catalog.

Select the track desired, then press ENTER to confirm the operation or PAGE to exit.

Deleting a track

Press the **PAGE** key to display the menu, select **TRACK**, **DELETE** and press **ENTER** to confirm.

The catalog that lists the tracks stored in the CompactFlash™ will show the **CURRENT** item indicating the track currently displayed.

Select the track to delete by the **CURSOR** key, then press **ENTER** to confirm. By selecting **CURRENT**, the track currently displayed will be deleted.

MARKER

Markers are used to identify points of interest to which names and symbols can be assigned.

NOTE: Marker names are displayed starting from the 32 NM chart range.

CURSOR MODE**Inserting a marker**

Move the cursor to the position desired and hold the **ENTER** key pressed for more than 2 seconds. A window will display the symbol and a name automatically assigned to the marker.



Use the **CURSOR** and **-ZOOM+** keys to change the marker symbol (8 symbols available) and name (max. 8 characters) according to the type of marker to store (e.g., fishing spots, wrecks, rocks, etc.). Press **ENTER** to confirm the insertion.

NOTE: The cursor can be moved to the desired position also by using most of the **GOTO** functions. See the *GOTO* Section for further details.

Changing a marker name/symbol/color

Position the cursor on the marker desired and press **ENTER**; a window will display the symbol and the name previously assigned to the marker selected. Use the **CURSOR** and **-ZOOM+** keys to change the marker name and symbol. Press **ENTER** to confirm the operation.

Deleting a marker

Position the cursor on the marker to delete and press **CLR**.

NAVIGATION MODE**Inserting a marker**

Press the **MARK** key to insert a marker at the boat's position. A window will display the symbol and the name automatically

assigned to the marker; to change the marker symbol and name according to the type of marker to store (e.g., fishing spots, submerged wrecks, rocks, etc.), use the CURSOR and the -ZOOM+ keys. Press ENTER to confirm the insertion.

Route to a marker
See the GOTO functions.

MAIN MENU

Storing a set of markers in the CompactFlash™

Press the PAGE key to display the menu, select MARKER, then STORE and press ENTER. Use the CURSOR key to change the default name and confirm.

The "MRK. STORED" message will confirm that markers have been stored correctly. Once stored, markers will disappear from the screen.

Each time a set of markers is stored in the CompactFlash™, the plotter memory is cleared and the indicator of the markers available is reset to the maximum value.

Recalling a set of markers from the CompactFlash™

Press the PAGE key to display the menu, select MARKER and then RECALL to open the marker catalog.

Use the CURSOR key to select the set desired and confirm, or press PAGE to exit.

Deleting a set of markers

Press the PAGE key to display the menu, select MARKER, DELETE and press ENTER to confirm.

The catalog that lists the sets of markers stored in the CompactFlash™ will show the CURRENT item indicating the set currently displayed.

Use the CURSOR key to select the set of markers to delete and to confirm. When selecting CURRENT, the set of markers currently displayed will be deleted.

SETUP

The SETUP menu allows setting the available options.

To access the SETUP menu, press PAGE repeatedly to display the menu, select the SETUP item, then use the CURSOR key to browse through the options and change the settings.

- Mode (BRIGHT/DAY/NIGHT)
Selects the colors suitable for the environment.
- Chart Rotation (ON/OFF)
Enables / disables the Chart Rotation function.
- Select Chart (ON/OFF)
Selects the chart to load from the CompactFlash™.
- Depth Contours (ALL/5m/10m/20m/OFF)
Selects the display of depth contours.
- Safety Contours (OFF/2m/5m/10m/20m)
Enables the display of the areas corresponding to the depth safety contour.
- Light Sectors (ON/OFF)
Enables / disables the display of light sectors.
- Spot Soundings (ON/OFF)
Enables / disables the display of depth point values.
- Names (ON/OFF)
Enables / disables the display of geographical names.
- Chart Boundaries (ON/OFF)
Enables / disables the display of chart boundaries.
- Overzoom (ON/OFF)
Enables / disables the Overzoom function.
- Presentation (INTER./U.S.)
Selects the symbols and colors of chart presentation.

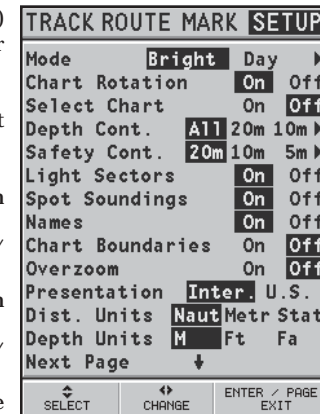

- Distance Units (NAUT/METR/STAT)
Selects distance units.
- Depth Units (M/FT/FA)
Selects depth units.
- Set Time (LOCAL/GMT)
Enters local time.
- Calibration (ON/OFF)
Sets the boat's position received by the GPS.
- GPS (EXT/INT)
Selects the built-in GPS (if available) or an external antenna.
- Bearings (TRUE/MAG)
Sets the magnetic mode for all bearings.
- Language (EN/FR/ES/DE/DK/IT/SV/NL/SU/NO)
Selects the language.

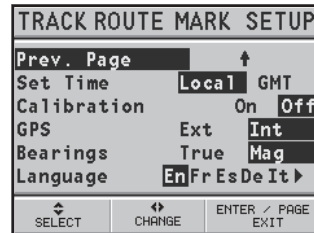

GPS inside
model

GOTO

The GOTO function allows creating a route or changing the target waypoint in the current route.

Route to a waypoint

Press the GOTO key, select WPT and press ENTER to open the GOTO Waypoint window. Choose a waypoint, press ENTER to confirm or PAGE to exit.

As the GEONAV will plot a new route, the waypoint selected will become the first waypoint in the route, whereas previous waypoints will be deleted. This function is available in Navigation mode only.

Route to a port

Press the GOTO key and select PORT by the CURSOR key. Choose the desired port (the latest 8 ports used will be highlighted) from the catalog displayed, then press ENTER to confirm. To scroll the list of ports quickly, press - ZOOM+.

If a port features secondary landing places, its name will show a small arrow at the end. To select the secondary landing place from the relevant window, press ENTER and then use the CURSOR key.

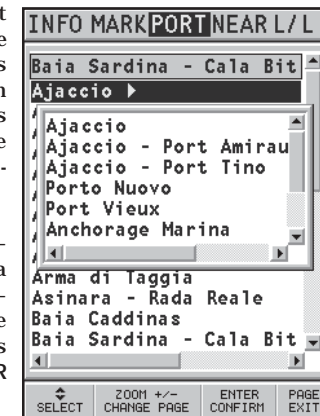

Once the desired port has been selected, the GEONAV will insert a waypoint in the port position and append the new leg to the existing route (if no route is available, the new waypoint will be connected to the boat's position).

Press the PAGE key to go back to Navigation mode and enable automatically the Autozoom function.

Route to a marker

Press GOTO and select MARK by the CURSOR key. The catalog displayed will list the symbol, the name and the insertion date/time of each marker.

By using CURSOR, choose the desired marker (the latest 8 markers used will be highlighted) from the catalog displayed, then press ENTER to confirm.

Once the desired marker has been selected, the GEONAV will insert a waypoint at the marker position and append the new leg to the existing route (if no route is available, the new waypoint will be connected to the boat's position).

INFO MARK PORT NEAR L/L		
HOME	18May01	14:57
PESCE	06Feb02	15:10
MARKER02	11Lug01	9:25
MARKER03	25Giù01	15:00
MARKER04	-----	---:--
MARKER05	13Sep01	18:40
MARKER06	31Ott01	20:30
MARKER07	23Nov01	23:59
MARKER08	-----	---:--
MARKER09	-----	---:--
MARKER10	-----	---:--
MARKER11	-----	---:--
MARKER12	-----	---:--
MARKER13	-----	---:--
MARKER14	-----	---:--

ZOOM +/- CLR ENTER PAGE
 SELECT CHANGE PAGE DELETE CONFIRM EXIT

Press the PAGE key to go back to Navigation mode and enable automatically the Autozoom function.

NOTE: To delete a single marker, select it from the GOTO Marker list and press the CLR key.

Route to the nearest service

NOTE: This option is available only with the NAVIONICS cartridges containing the Port Services features. It allows finding and heading for the nearest port featuring the service desired.

Press GOTO, select NEAR by CURSOR, choose the desired ser-

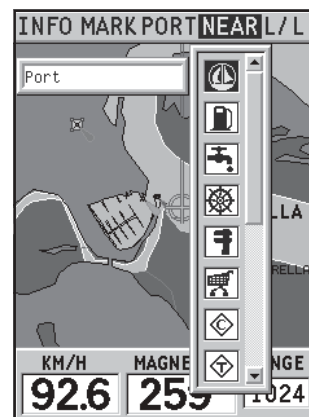

vice and press ENTER to confirm, or CLR to cancel the operation. The GEONAV will show the three destinations closest to the boat's position (if in Navigation mode), or to the cursor's position (if in Cursor mode), and position automatically on the closest destination (flashing).

Select one port at a time by using the CURSOR key; a window will show the distance and the time to arrive (estimated on the boat's current speed). Press ENTER to confirm the selection.

The GEONAV will insert a waypoint in the port selected, delete automatically the existing route (if in Navigation mode), or append the waypoint to the existing route (if in Cursor mode), then go back to Navigation mode and enable automatically the Autozoom function.

Route to a point (Lat/Lon)

Press GOTO and select L/L by the CURSOR key. Enter the geographical coordinates desired and confirm by pressing ENTER.

The GEONAV will move the manual cursor to the position selected; insert a waypoint by pressing ENTER or a marker by pressing MARK.

Tide or current forecast at the nearest survey station

NOTE: This function is available only with the NAVIONICS cartridges containing Tides and Currents data.

This function allows displaying, within the space of twenty-

four hours with respect to the selected date, the tide level and tidal current speed and direction at a survey station in the vicinity.

Unlike the estimated data shown in the Info window, this forecast is much more accurate, being supplied directly by tidal surveying stations.

Press **GOTO**, select **NEAR** by the **CURSOR** key, choose the Tides or Currents service, then press **ENTER** to confirm. The **GEONAV** will allow selecting one of the three nearest Tides and Currents stations. Use the **CURSOR** key to choose the station desired and to confirm.

A window will show the information reported below.

Tide station

- Name of the station
- Forecast reference date
- Time and height with respect to the cursor's position in the graph
- Time and height of high/low water
- Dawn and sunset time
- Moonrise and moonset time
- Moon phase
- Tide level graph (24 hours)

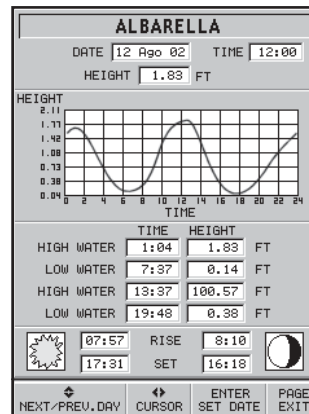

Tidal current station

- Name of the station
- Forecast reference date
- Time, speed and direction with respect to the cursor's position in the graph
- Time, speed, direction and slack time of daily flood and ebb streams
- Dawn and sunset time

- Moonrise and moonset time
- Moon phase
- Tide level graph (24 hours)

In the both cases above, the default date is today. A different date can be set by pressing **ENTER** or **-ZOOM+**.

NOTE: The same information can be accessed by positioning the manual cursor on the icon of a Tides or Currents station, and pressing **ENTER** to confirm.

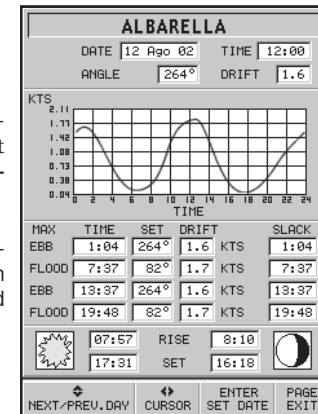

AUTOPILOT

The GEONAV allows a boat equipped with an autopilot to follow automatically the entered route, compensating for any diversion caused by external conditions (wind, currents, etc.).

The GEONAV will display the “PROXIMITY TO WAYPOINT” message to warn the user that the boat is about to reach the target waypoint.

The GEONAV will display the “END OF TRIP” message to warn the user that the boat is about to reach the last waypoint in the route.

IMPORTANT: In order to avoid sudden change of course, it is always recommended to deactivate the autopilot when editing and/or creating a route.

TABLE OF CONTENTS

INTRODUCTION	4
CHARACTERISTICS	5
INSTALLATION AND PRECAUTIONS	8
CONNECTIONS	10
CARTRIDGE INSTALLATION	11
KEYBOARD	13
DIAGNOSTIC	14
NAVIONICS ELECTRONIC CHARTS	15
GRAPHIC ITEMS	19
FUNCTIONAL CHARACTERISTICS	21
GETTING STARTED	27
OPERATING MODES	30
SATELLITE WINDOW	31
NAVIGATION WINDOW	33
MENU	34
DEPTH SOUNDER WINDOW	35
INFO WINDOW	36
TRIP WINDOW	37
ROUTE	38
TRACK	43
MARKER	45
SETUP	47
GOTO	49
AUTOPILOT	54